



## Operating Instructions Vibratome Series 1000 Classic – Tissue Sectioning System

Your Complete Source for Fresh or  
Fresh Fixed Tissue Sectioning Applications

Distributed in the UK by



Tel 01708 227140  
Email [sales@slaughter.co.uk](mailto:sales@slaughter.co.uk)



Rev. May 2000

## TABLE OF CONTENTS

<b>1.0</b>	<b>INSTALLATION</b>
1.1	Unpacking and Inspection
1.2	Power Requirement
1.3	50 Hz Operation
1.4	Physical Location
<b>2.0</b>	<b>PRINCIPLES OF OPERATION</b>
2.1	Introduction
2.2	System Description
2.2.1	Carriage Assembly
2.2.2	Specimen Height Control Assembly
2.2.3	Electronics Assembly
2.2.4	Lamp/Magnifier Assembly
2.3	Controls and Adjustment
2.3.1	Front Panel Controls
2.3.2	Specimen Height Control
2.3.3	Additional Adjustment
<b>3.0</b>	<b>OPERATIONAL PRECAUTIONS</b>
3.1	Operator Field
3.2	Instrument Related
<b>4.0</b>	<b>OPERATING INSTRUCTIONS</b>
4.1	General Concepts
4.2	Specimen Mounting
4.3	Blade Selection, Preparation, and Mounting
4.4	Liquid Bath Trimming
4.5	Normal Sectioning
4.6	Section Retrieval
<b>5.0</b>	<b>SPECIFICATIONS</b>
<b>6.0</b>	<b>ACCESSORIES</b>
6.1	Standard Accessories
<b>7.0</b>	<b>MAINTENANCE</b>
7.1	Component Replacements
7.1.1	Fuse
7.1.2	Florescent Lamp
7.2	Cleaning
7.2.1	Specimen Bath Area
7.2.2	Magnifier Lens
7.2.3	Cabinet
<b>8.0</b>	<b>SERVICE INFORMATION</b>
8.1	Warranty Policy
8.2	Service Policy
8.3	Additional Help

the instrument back panel to ensure that the proper version has been shipped for your local supply voltage.

	<b>054018</b>	<b>054026</b>
Voltage:	115/100 VAC nominal	230 VAC nominal
Frequency:	60 Hz or 50 Hz	60 Hz or 50 Hz
Current:	1 Amp maximum	0.5 Amp maximum

**IMPORTANT:** The Vibratome 1000 is supplied with a three-conductor power cable with a three terminal plug that affords an earth ground. For continued protection against electrical shock hazards, the electrical outlet used **MUST** be properly wired (per U.S. National Electrical Code or International Electrotechnical Commission) three-terminal type. The use of an adaptor to a two-terminal outlet is **NOT RECOMMENDED**.

### 1.3 50 Hz OPERATION

The Vibratome 1000 models are designed for dual frequency (50hz/60Hz) operation. At the time of shipment, the units are configured for either 50 or 60 Hz based on the order. However, if a 60 Hz unit needs to be re-configured for operation on a 50 Hz power supply frequency, a minor modification may have to be made. It consists of the addition of one or both of the shim washers provided in the Accessory Package to the instrument to restore sufficient vibratory amplitude.

The operator should first become familiar with the instrument by reading this manual entirely and performing trial sections with expendable specimens. If the range of amplitudes available is sufficient for the applications intended, it is best to use the instrument as is. If the amplitude at maximum setting is insufficient, proceed with the following:

Referring to Figure 1, note that the solenoid and the cover above it had been omitted for clarity.

1. Remove the screw holding the solenoid plunger to the right side spring blade.
2. Separate plunger and spring blade by pushing spring blade to the right while pushing plunger to the left through the vacant screw hole.
3. Scrape off excessive thread locking compound (blue-white deposit), if present, from contact areas between the two parts.
4. Using a pair of tweezers, insert both shim washers provided between the two parts as shown.
5. Reinstall screw and tighten.
6. Turn instrument power on and increase amplitude towards "10". If a loud rattling noise can be heard from the solenoid, remove one of the shim washers. Otherwise, the instrument is ready for use at 50 Hz.

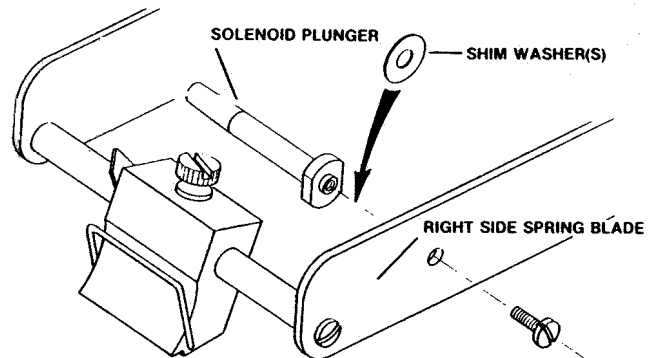

**Placement of Figure 1. Shim washer insertion for 50 Hz operation**

### 1.4 PHYSICAL LOCATION

The Vibratome 1000 should be placed on a suitably stable bench. Excessive jarring during operation may affect the quality of the sections generated.

The immediate area chosen should be well illuminated to ease the handling of specimens and sections generated.

## 2.0 PRINCIPLES OF OPERATION

### 2.1 INTRODUCTION

## 1.0 INSTALLATION

### 1.1 UNPACKING AND INSPECTION

The Vibratome 1000 Sectioning System is shipped complete in one carton. The Carton should contain the following items:

1. Vibratome 1000 instrument with integral Lamp/Magnifier.
2. Accessory Package consisting of:
  - 1 Blade Angle Indicator
  - 2 Specimen Mounting Blocks
  - 1 Instrument Cover
  - 1 Rubber Syringe
  - 1 Package of Razor Blades
  - 2 Spare Fuses (4 Spare Fuses for 054026)
  - 1 Bottle of Specimen Adhesive
  - 2 Shim Washers
3. This Operator's Manual

When unpacking, check carefully that all of the above items are present. If there are discrepancies please notify the distributor through which the Vibratome 1000 is obtained.

If any items are found to have been damaged during transit, the carrier and the supplier should be notified promptly for restitution.

### 1.2 POWER REQUIREMENTS

The Vibratome 1000 is available in two versions for operation under different supply voltages. Prior to connecting power to the instrument, check the Product Number (054XXX) and the input voltage markings on

The Vibratome 1000 Sectioning System provides a versatile means of sectioning fresh or fixed, animal or plant tissues. It employs a vibrating blade principle, which allows sectioning without freezing or embedding. The creation of artifacts, the alteration of morphology, the destruction of enzyme activities, and other deleterious effects inherent in freezing or embedding procedures are thus avoided.

The patented vibrating blade principle moves the sectioning blade edge in a reciprocating arcuate path as it penetrates the specimen. The reduced effective edge angle from the transverse movements, together with the lateral distribution of the cutting edge penetrating pressure, minimize elastic deformation of soft tissue specimens that are simply held or capsulated in position during the sectioning operation. Uniform sections, as such, can be made of delicate soft tissue specimens. Sections made are free of observable compressive distortion in the direction of cut, as would be typical with conventional microtomes. Preservation of ultrastructure is maintained in the sections from a lack of cellular damage on their surfaces.

Sectioning takes place in a liquid bath. The liquid serves to lubricate the sectioning blade, to maintain specimen temperature, to enhance or preserve desirable characteristics of the specimen. It also serves to facilitate the easy retrieval of the sections generated.

Ordinary injector type razor blades are used for the sectioning. With expensive blades of exotic materials used in conventional microtomes not being required, the costs of operation and maintenance are significantly reduced.

The operation of the Vibratome 1000 is semi-automatic, requiring that each sectioning cycle be only initiated by the operator. Upon completion of a section, the instrument will return to a "ready" mode awaiting section retrieval or the initiation of another cycle. The amplitude of the blade vibration, the speed of blade advance, the presentation angle of the blade are operator selectable to achieve optimum results with varied specimens.

The simplicity of preparation and operation makes practical the usage of the Vibratome 1000 by technicians and students. With modest care the Vibratome 1000 should be capable of many years of service.

## 2.2 SYSTEM DESCRIPTION

The Vibratome 1000 consists of four major functional assemblies. See Figure 2 for their locations.

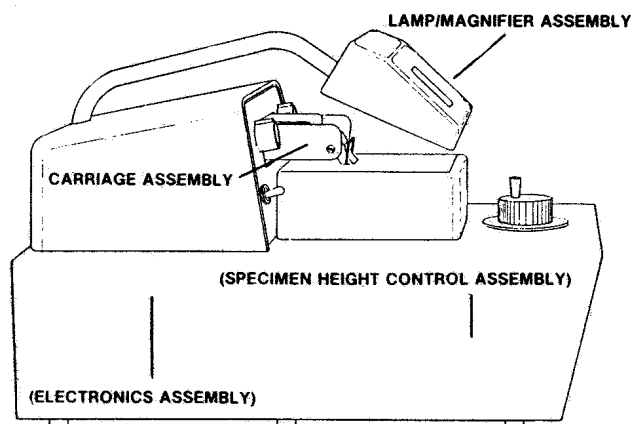

**FIGURE 2. VIBRATOME 1000 FUNCTIONAL ASSEMBLIES**

### 2.2.1 Carriage Assembly

The Carriage Assembly produces the vibratory movements as well as the horizontal advancement of the sectioning blade.

The vibratory movements are generated by an intermittently driven solenoid acting on a sub-assembly consisting of two flat springs and the blade holder. The intermittent pulling force of the solenoid against the springs causes the blade holder, and hence the sectioning blade, to vibrate about its static position.

While remaining parallel to its static position, the blade edge is mechanically constrained to trace an arcuate or curved path when

vibrating. The orientation of this arcuate path relative to the direction of advancement into the specimen is essential to producing good sections. Figure 3 shows an exaggerated diagrammatic representation of the arrangement.

In a typical vibratory cycle, the blade edge is retracted at one end of the arcuate path. It is accelerated while extending towards the specimen until, at maximum extension, it attains maximum lateral speed. The blade edge is then decelerated and retracted towards the opposite end of the arcuate path. The cycle is then completed with the same sequence reversed.

It can be seen then, when advancing into the specimen, the greatest amount of cutting takes place while lateral speed of the blade edge is near maximum. When the lateral speed is high relative to the advance speed, the effective cutting edge presentation angle is significantly reduced. Analogously, the effective slope up an incline is reduced by transversing diagonally.

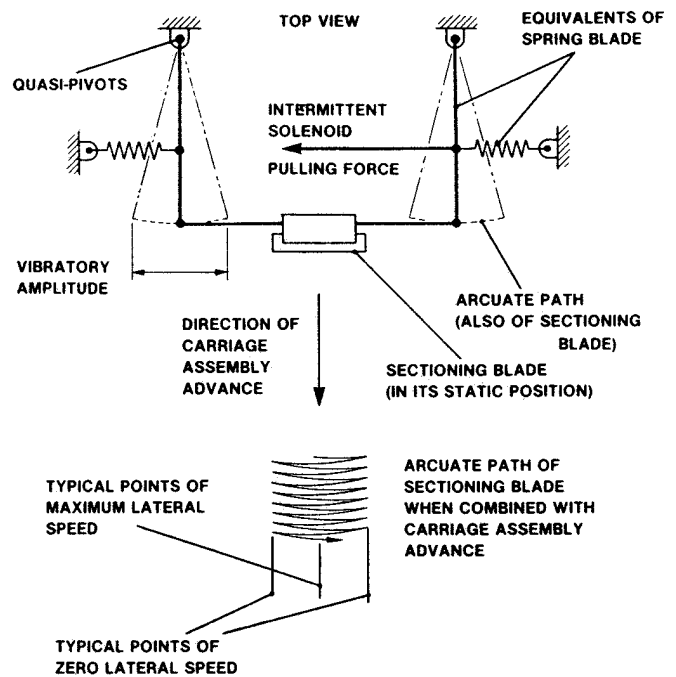

**FIGURE 3. VIBRATOME 1000 SECTIONING SCHEMA**

It can also be seen that, since the blade edge movement during penetration of the specimen is essentially lateral. The pressure of penetration imparted by the blade is distributed laterally. The effect, combined with low effective cutting edge angle, allows penetration of the specimen with minimal resistance. Fresh or fixed tissue specimens can be sectioned with minimal distortion in the direction of advance, and hence not requiring the freezing or embedding necessitated by conventional microtomes.

The horizontal advancement of the Carriage Assembly is produced by a reversible variable speed motor driving through a speed reduction gearbox, a pulley-belt combination and finally through a treaded shaft-nut combination. This driving arrangement has been configured to economically provide controlled steady advance speeds.

The path of the Carriage Assembly along the advancement direction is guided by ball bearings traveling on two precision track rods. High mechanical rigidity is maintained by this arrangement to reduce extraneous and undesirable relative movements between the sectioning blade and the specimen.

### 2.2.2 Specimen Height Control Assembly

The thickness of sections generated is controlled by the raising of the specimen incrementally. Since the sectioning blade remains stationary

vertically, the increment through which the specimen is raised correlates with the section thickness.

The raising of the specimen is accomplished through a micrometer subassembly located under the specimen bath. Rotary movements of the section thickness control knob are translated to vertical movement by a micrometer subassembly. Connection between the section thickness control knob and the micrometer subassembly is made through a pulley-belt combination.

A detent mechanism has been incorporated in the Specimen Height Control Assembly to provide tactile click stops at 5 um increments. As such, when raising the specimen for an intended section, the number of clicks felt on the control knob equates with the same number of 5 um multiples in the intended section thickness. Older Vibratome 1000 products utilized a 10 um detent mechanism.

### 2.2.3 Electronics Assembly

The principal function of the Electronics Assembly is for the operator control of the Carriage Assembly movements. The vibratory amplitude and horizontal advancement speed are separately controlled.

There are essentially three operating states for the Electronics Assembly:

- A. Sectioning blade advancing FORWARD with vibratory movement ON.
- B. Sectioning blade in REVERSE with vibratory movement OFF.
- C. Sectioning blade in a rearmost "READY" position with vibratory movement OFF.

When the instrument power is first turned on, the sectioning blade will automatically reverse in state "B" until it stops in state "C".

Each sectioning cycle needs only be initiated by the operator. Once state "A" is activated, the sectioning blade will advance at operator selected forward speed and amplitude until it reaches the forward end-of-travel. The sectioning blade will then automatically reverse in state "B" until state "C" is once again reached. It will then remain in state "C" until another cycle is activated by the operator.

When in state "A", a momentary override of the preselected forward speed is available. The sectioning blade can be made to advance at a maximum forward speed. If so desired, between the rearmost "ready" position and the specimen.

The speed of reversing in state "B" is independent of preselected forward speed. It is always at maximum.

At any time during the sectioning cycle, operator override of the semi-automatic operation is available. When advancing forward in state "A", the section can be made to reverse in state "B", and vice versa.

The electronic circuitry in the Electronics Assembly has been configured for simplicity and reliability. All components used have been conservatively specified, and are carefully protected against accidental wetting on bath fluid spillage.

### 2.2.4 Lamp/Magnifier Assembly

The Lamp/Magnifier Assembly consists of a miniature fluorescent lamp and a 2X powered magnifier mounted in a housing over the specimen area. Its purpose is to facilitate the close examination of the specimen during sectioning.

The fluorescent lamp was chosen for its even illumination and its minimum heat generation. The standard lamp can be replaced with readily available deep blue and ultraviolet versions for unique applications. See the Accessory Section of this manual for details.

## 2.3 CONTROLS AND ADJUSTMENTS

The instrument controls and adjustments are separated into three groups; Front Panel controls, Specimen Height Control, additional adjustments. These groups allow for the easy use and control of the instrument for the best sectioning results. They are described in detail by their respective groupings in the following sections. See Figure 4 for a detailed view of their locations.



**FIGURE 4. VIBRATOME 1000 CONTROLS AND ADJUSTMENTS**

### 2.3.1 Front Panel Controls

- A. Power  
This is a three position switch that functions as the main power switch for the instrument. With switch at the bottom OFF position, power is disconnected from all points of the instrument EXCEPT the fuse holder.  
NOTE: UNPLUG power cord before replacing instrument fuse.

With switch in the middle ON position, the instrument is entirely functional except for the fluorescent lamp. To start lamp, the switch is pushed to the top LAMP position. Upon release of switch, it will return to the ON position. The fluorescent lamp will remain on until power is turned off.

- B. This is a three position switch that controls the direction of travel of the sectioning blade, together with the functioning of its vibratory movements. In initiate a sectioning cycle, the switch is pushed to the top START/FAST FWD position. The sectioning blade will advance forward at maximum speed when switch is held at its top position. Upon release of the switch, it will return to its middle FWD/AUTO REV position. The sectioning blade will continue advancing forward at the operator preselected SPEED and AMPLITUDE control settings. At a short distance past the specimen vise, the sectioning blade will automatically reverse direction. Reversing stops when the rearmost "ready" position is reached.

At any time during forward advance, pushing switch down to REV position will reverse the direction of travel. Similarly, during reverse, pushing the switch up will resume the forward advance.

- C. Speed

This knob controls the relative speed of the sectioning blade while it is advancing forward with the DIRECTION switch in the FWD/AUTO REV position. The sectioning blade will be stopped at the 0 setting and will advance forward at maximum speed at

the 10 setting. At intermediate settings, the speed will vary proportionally.

D. Amplitude

This knob controls the relative amplitude of the lateral excursion of the sectioning blade vibratory movements. The control settings will only be in effect while sectioning blade is advancing forward. No vibratory movements will be present during reverse or at the 0 setting. Vibratory amplitude will be at a maximum at the 10 setting. At intermediate settings, the amplitude will vary proportionally.

2.3.2 Specimen Height Control

E. Section Thickness

This knob controls the relative height of the specimen. The thickness of sections generated correlates with the incremental increases of specimen height with this knob.

The settings are graduated in  $\mu\text{m}$  (10<sup>-6</sup> meters) and are arbitrary only. A setting of "45", for example, is of little significance in itself. To generate a section of 10  $\mu\text{m}$  thickness, the setting should be increased to "55".

While CW (clockwise) rotation of this knob raises and CCW (counterclockwise) rotation lowers the specimen, these settings are consistent only in one direction of rotation (CW, in most instances). For example, a CW rotation to a setting of "30" followed immediately by a CCW rotation to "25" does not lower the specimen by 5  $\mu\text{m}$ . To lower the specimen by a true 5  $\mu\text{m}$ , this knob must be rotated CCW approximately one full turn past "25", then rotate until it is once again at "25". In other words, to compensate for backlash, the end setting for any changes of setting must be approached after having rotated CW for at least one turn.

Click stops at 5  $\mu\text{m}$  increments can be felt when rotating this knob. In most usage's, this feature eliminates the requirement to carefully read the settings while incrementing. Click stops can simply be counted to equate with the number of multiples of 10  $\mu\text{m}$  to be incremented.

2.3.3 Additional Adjustments

F. Sectioning Blade Angle Adjustment

The presentation angle of the sectioning blade relative to the plane of the section is adjustable to suit operating conditions and specimen types. The adjustment is made by rotating the section blade holder on its mounting rod, after having loosened the serrated screw over the blade holder.

A Blade Angle Indicator has been provided in the Accessory Package for this purpose. The blade angle can be read from the indicator by placing it against the left side of the blade holder, with the notch resting on the blade holder mounting rod and the lower edge over the specimen bath. See Figure 5 for illustration.

Tighten the serrated screw firmly to prevent accidental loosening during sectioning. See also the immediately following adjustment on the blade holder.

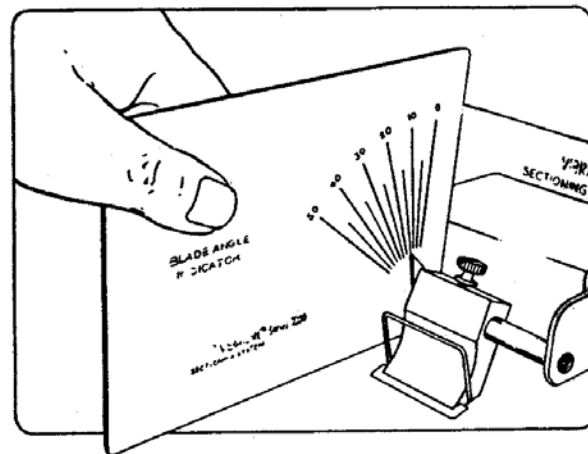

FIGURE 5 BLADE ANGLE INDICATOR USAGE

G. Sectioning Blade Lateral Position Adjustment

Occasionally, with large specimens, it may be desirable to position the sectioning blade holder away from its normal central position on its mounting rod. When the width of a large specimen approximates the sectioning blade edge length, proper lateral positioning of the sectioning blade may have to be made over the specimen for full sections to be generated.

Since the same serrated screw used for sectioning blade angle adjustment is used for this adjustment, the blade angle may change and should be rechecked.

H. Specimen Vise Lateral Position Adjustment

The lateral positioning of the specimen vise is adjustable to allow for the approximate centering of the specimen within the bath, if so desired. Since one of the jaws of the specimen-clamping vise is stationary, the usage of specimen mounting blocks of varying widths will allow for adjustable specimen mounting.

I. Specimen Vise Tilting Adjustment

Tilt adjustment about one axis (front to back) is possible on the specimen vise for the approximate leveling of the specimen surface. After loosening the plastic headed locking screw between the front of the vise and the specimen bath wall, the entire specimen vise can be tilted to either side.

If additional leveling is required, tilting of the specimen in another axis (side to side) is possible by tilting the specimen-mounting block when clamping it into vise jaws. Full three axis control is available with the optional rotating stage assembly (053760).

3.0 OPERATIONAL PRECAUTIONS

The operator should read this manual in its entirety before operation and follow all instructions carefully during operation. The following precautions are cited so that the operator may avoid those actions, which may be injurious to himself, or may damage the instrument, or may adversely affect its performance.

3.1 OPERATOR RELATED

Observe warning messages on the rear of the instrument, also reproduced in Figure 6. There are no operator serviceable components in this instrument aside from those described in the "Component Replacement" Section.

**WARNING—ELECTRICAL SHOCK HAZARD  
WHEN OPEN. DO NOT OPEN COVER.  
REFER SERVICE TO QUALIFIED  
SERVICE PERSONNEL.**

**CAUTION—FOR CONTINUED PROTECTION  
AGAINST FIRE HAZARD REPLACE ONLY  
WITH FUSE OF SAME TYPE AND RATING.**

**FIGURE 6. VIBRATOME 1000 REAR PANEL MARKINGS**

Opening of any instrument panels or cover is strongly discouraged since line voltage is prevalent inside the instrument. All service work should be referred to a Vibratome Company Service Representative. See "Service Information" section for details.

The outside surfaces of the instrument are kept at ground potential and serve as a barrier for protection against accidental electrical shocks. For continued protection, proper connection to an earth ground must be maintained. The path provided for this connection is through the third terminal of the power cord plug. The power outlet used must therefore be a three terminal type that affords an earth ground. The usage of an adaptor plug to a two terminal outlet is not recommended since a positive earth connection is not afforded.

When fuse replacements are made on the rear of the instrument, the power cord should be first disconnected from the power outlet. This procedure insures against shocks in the case where the power outlet is not properly polarized or wired.

Exercise due caution in the handling of the sectioning blades. The edges on these blades are normally very sharp. To avoid unintentional cuts, handle the blades with tweezers and hold them by their blunt ends with thumb and index finger. When disposing of used blades, apply common "Scotch" tape over the cutting edge or wrap the entire blade with paper.

When manipulations or adjustments are made in the specimen area, the sectioning blade should be removed from its holder first to avoid accidental bumping of the blade edge.

The cyanoacrylate based Specimen Adhesive provided in the Accessory Package will bond human skin to other materials or skin to skin very readily. Avoid contact with fingers when using. When contact occurs, allow adhesive to air dry before wiping with an acetone soaked towel. When unintentional bonding of skin occurs, separate by a "peeling" (rather than pulling) action after applying acetone to bond area.

### 3.2 INSTRUMENT RELATED

Before unusual or potentially aggressive solutions are introduced into the specimen bath, their compatibility with the polymeric materials used in the bath and surrounding areas must be assured. The specimen bath itself is molded from polypropylene while fluid seals within the bath are molded from nitrile rubber. The paint on outer surfaces of the instrument is of a polyurethane formulation.

When filling or emptying the specimen bath, avoid spilling of the bath solutions onto other parts of the instrument. Although all electrical components within the instrument have been either shielded or sealed against fluid contact, there may be long-term deleterious effects from corrosion or salt accumulation.

While sections are being generated from specimens, and in particular when fragile thin sections (10  $\mu$ m thickness or less) are generated, avoid jarring the instrument or the bench it is on. Excessive movement of the bath solution may cause the breaking up of the sections.

When fuse replacements are required, the same type and rating of fuse must be used. See the instrument rear panel markings for fuse type and rating.

### 4.0 OPERATING INSTRUCTIONS

### 4.1 GENERAL CONCEPTS

Because of the diversity of specimen types, sizes, shapes conditions, preparations, etc. that may be encountered when sectioning with the Vibratome 1000 instrument, specific recommendations can not be made regarding the control settings to be used. Optimal control settings for each application must be arrived at empirically with expendable specimens that are similar to the routine sections to be sectioned.

As described in the previous "Principles of Operation" section, the principal feature that allows the sectioning without freezing or embedding is the essentially lateral blade movement during penetration of the specimen. As such, the relationship between the lateral speed (proportional to the amplitude setting) and the advance speed, or the amplitude-to-advance speed ratio, is a key parameter in the sectioning performance of varying specimens.

In general, rigid specimens may be sectioned with a low amplitude-to-advance speed ratio (i.e. high speed setting), while soft specimens are best sectioned with a high amplitude-to-advance speed ratio (i.e. high amplitude setting and/or amplitude setting increased. When the section breaks up from over agitation, the amplitude setting should be reduced.

In normal sectioning, the specimen is lifted upwards elastically as the blade advances. See Figure 7 for an illustration. Small clearance will actually exist with the specimen when the blade is reversing after a section. This lifting phenomenon varies with control settings and is more pronounced with softer specimens, higher advance speeds, higher blade presentation angles, and particularly with thicker sections being generated. In general, it does not materially affect the section performance provided that control settings are not changed during a section and gradual transitions are made in section thickness changes (especially going from thick section to thin section), when serial sectioning.

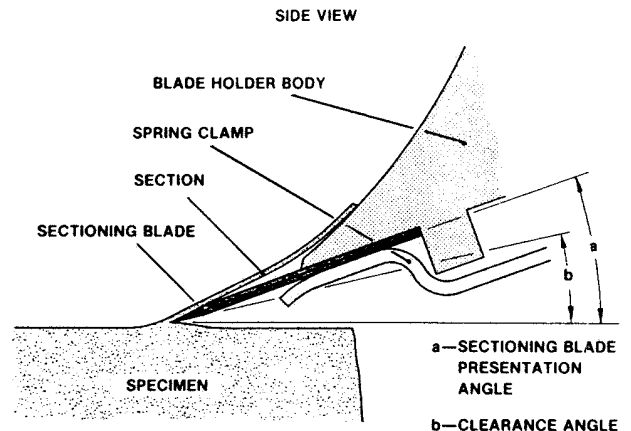

**FIGURE 7 – VIBRATOME 1000 BLADE-SPECIMEN RELATIONSHIP**

### 4.2 SPECIMEN MOUNTING

#### 4.2.1 Direct Mounting

Specimens rigid enough to be held firmly in the specimen vise without damage may be clamped directly. Observe that excessive clamping force by the vise jaws may distort specimen.

Specimens that are less self-supporting (e.g. a leaf) may be "sandwiched" between supporting strips or soft material such as balsa wood, elder pith or Styrofoam and clamped in the specimen vise as a unit. The supporting material should section easily and may be separated from the tissue section in the bath area after sectioning. To maintain sufficient rigidity the specimens should be clamped as close to the vise jaws as possible.

#### 4.2.2 Adhesive Mounting

Specimens that are fragile and difficult to position properly may be adhesive mounted directly or indirectly to the specimen mounting blocks supplied in the Accessory Package. A bottle of cyanoacrylate base specimen adhesive is also included in the Accessory Package and should provide reliable and essentially instantaneous mounting of a variety of

materials (e.g. fresh liver, heart, fixed brain and kidney and fragile botanical specimens).

Specimens small enough to fit onto one of the surfaces of the specimen-mounting block may be attached directly. The specimen-mounting block is in turn clamped into the vise jaws for sectioning.

In cases where the specimen area is too large, an intermediate plate of glass (e.g. a complete, or portion of, standard microscope slide) may be used. A small Specimen Mounting Tray is also available as an additional accessory (053744).

Note that when using the adhesive, caution should be exercised since it will bond human skin readily. See "Operational Precaution" section for details.

The surfaces onto which specimen is attached must be clean, dry and free of residual adhesives from previous applications. The specimen mounting blocks have been hard surface coated and should withstand repeated scrapings with razor blades. The surface of the specimen to be attached should be blotted if possible, gently with absorbent paper to remove excessive fluids that may interfere with adhesive action.

Sufficient adhesive should be applied to the mounting surface to allow complete attachment of the specimen. Experience has shown that most sectioning performance anomalies can be attributed to partial attachment of specimens. Since bonding is very rapid, initial positioning of the specimen on the mounting surface should be done carefully. If the specimen will permit, slight pressure will enhance the adhesive action.

For specimens that are insufficiently rigid in the fresh condition for adhesive mounting, prior fixation may be performed if not detrimental to the phenomenon or process for which specimens are being studied. Alternately, the specimens may be encapsulated in a support media such as agar, gelatin, or paraffin. The block of support media, together with the specimen, may be trimmed to size and adhesive mounted upon solidification.

Note that in all cases requiring adhesive mounting, thickness of the specimen should be kept to a practical minimum to maximize rigidity. Gross hand trimming should be performed to ensure that top surface is uniformly flat, so that the time required for initial trimming with the sectioning blade is reduced.

#### 4.3 BLADE SELECTION, PREPARATION, AND MOUNTING

There are two standard types of blades that can be used for sectioning. The first of these is the single edge injector type razor blade. The second of these is the thinner double edge type razor blade. Good quality blades of both types should be readily available from The Vibratome Company or your local distributor.

Depending on the type of specimens sectioned, the type and brand of blades may affect the instrument performance. The operator is encouraged to experiment with different brands. For higher quality sections, a sapphire knife is available (053237). This knife fits in the standard blade holder and provides a superior means for sectioning tissue.

For some applications, particularly with soft tissues when minimal sections (10  $\mu$ m or less) are to be generated, the double edge type has been found to be a better choice. In order that these double edge type be used, they must be slightly modified. The modification consists of breaking the blade into two usable halves with a single edge each. The two halves are connected only at the two blunt ends of the blade. By bending sharply with tweezers or small pliers, the two halves can be separated for use.

Before either type of blade is used for sections, it must be cleansed thoroughly of oils or silicon's. A suggested procedure consists of soaking in xylene for approximately 10 minutes, followed by thoroughly flushing with acetone and air-drying.

Caution must be exercised in the handling of the blades to not let the blades to not let the blade edge contact any object. Resulting microscopic damage to the blade edge may cause localized tearing of the specimen. Caution must also be exercised to prevent operator injury from accidental cuts.

The sectioning blade is held in the blade holder by the action of a spring clamp against the bottom of the blade holder body. A wire formed release lever is provided in front of the body to release the spring action. Pulling this lever away from the body will separate the spring clamp and the body. The sectioning blade, held by its blunt ends between index finger and thumb, can be inserted while spring clamp and body are separated. See Figure 8 for illustration. The blade must be seated fully against the stop in the back of the separation.

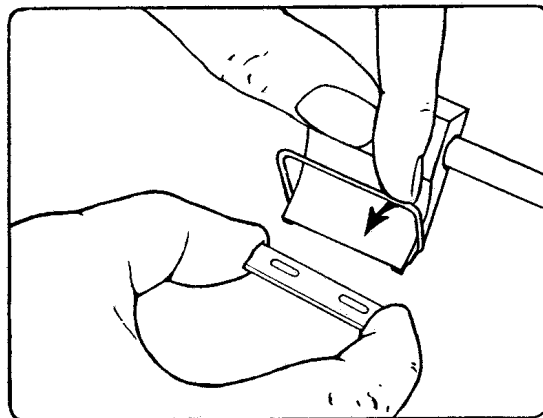

**FIGURE 8 – SECTIONING BLADE MOUNTING**

The presentation angle of the sectioning blade is adjusted by rotating the blade holder on its transverse mounting rod. Although the presentation angle is adjustable between 0 degrees and 50 degrees, the usable range for most applications will be between 15 degrees and 25 degrees. See Figure 7 for an illustration of the blade-specimen geometric relationship. See also Figure 5 on usage of Blade Angle Indicator.

Some experimentation will be required to arrive at a blade presentation angle best suited for particular specimens under particular operating conditions. Too small a presentation angle will result in either the compression and rubbing of the specimen from a lack of clearance angle, or the interference of the spring clamp against the specimen. Too large a presentation angle will result in the non-uniformity of cut, the distortion of the specimen in the direction of advance, and in some cases the tearing of the specimen from its mountings. A suggested starting point of 20 degrees will suit most applications.

#### 4.4 LIQUID BATH PREPARATIONS

The purpose of the specimen bath is four-fold: to lubricate the blade when section is being generated; to prevent heating or drying of the specimen; to enhance or preserve desirable characteristics of the specimen; to facilitate the easy retrieval of the fragile sections generated.

Any fluid, compatible with polypropylene and nitrile rubber, that would best preserve or maintain the phenomenon or process for which the specimen is being studied may be used. A wide variety of fluids have been used successfully ranging from a balanced saline solution, buffered phosphate solutions, alcohols, hydrocarbon, distilled or deionized water, glycerols, mineral oils and formalin.

The fluid chosen should not cause the rapid swelling of the specimen. In the case such a fluid must be used, the specimen should be allowed to swell in the fluid before mounting. Normal saline is recommended for fresh animal tissue. Distilled or deionized water may be used for fixed animal tissues and botanical specimens. Cautions must be exercised when the use of toxic or inflammable fluids may be injurious to the operator.

Any bath fluid may be externally cooled (or heated) to achieve maximum sectioning consistency or to preserve enzymatic activity. In most applications the bath fluid is best maintained at just above freezing with the immersion probe of a separate cooling unit. See the "Accessories" section for some sources. Alternately if bath fluid is aqueous, ice can be added.

After setting the desired sectioning blade presentation angle, the bath should be filled to a level where the blade edge is submerged by

approximately 3 to 4 mm. This level should allow the section to either ride directly upon the curved front of the blade holder or float in front of the blade itself.

#### 4.5 INITIAL GROSS TRIMMING

Prior to sectioning, gross trimming of the specimen top surface with the sectioning blade, to achieve flatness, is required.

When the specimen and mounting block is clamped into the specimen vise in the desired orientation relative to the blade advance, the top surface of the specimen should be kept approximately horizontal. Two means of adjustment are available, the tilting of the specimen vise and the tilting of the specimen mounting block within the vise jaws.

The speed and amplitude settings should be initially set to the "0" position. The sectioning blade is then advanced to just short of the specimen by momentarily holding the direction switch in its top position. With the sectioning blade close to the specimen, their relative heights may be gauged approximately. The specimen should then be raised (or lowered) to a position just below the blade edge.

Trimming the specimen may then be performed by serial sectioning until complete sections can be made of the area of interest on the specimen. With unfamiliar specimens, to minimize the change of specimen damage, the advance speed should be at a low setting while the amplitude should be at a medium setting. The section thickness should be incremented at a suggested 50 um interval.

If the specimen permits, the speed and section thickness may be gradually increased to reduce trimming time. Caution should be exercised when increasing to not distort or tear the specimen from its mounting.

#### 4.6 NORMAL SECTIONING

After proper specimen top surface flatness has been achieved by gross trimming, preparation for sectioning can be performed. The procedure consists of generating a few sections at the eventual control settings and section thickness increment. The purpose of this procedure is to compensate for the specimen-lifting phenomenon noted in the "General Concept's" section. This effect can be observed by noting that the first, and possible the next few sections, will either non-existent or too thin. Thereafter, when changing from thick sections to a much thinner section, the procedure should be repeated.

Assuming that the optimal control settings have been predetermined as noted in the "General Concepts" section, sectioning may proceed at these settings. Note that while a section is being generated, the control settings must not be varied otherwise the thickness may also vary within the section. Note also that the section thickness may be incremented (in the clockwise direction) only after the sectioning blade has past the specimen while reversing. Note also that the section thickness control knob may not be rotated counterclockwise without subsequently compensating for internal backlash as noted in the "Specimen Height Control Assembly" section.

With the instrument operation being semi-automatic, each sectioning cycle need only be initiated by the operator. The instrument will then complete the section, unattended if desired, and return to the rearmost "ready" position. The "fast forward" mode may be used to speed the sectioning blade between the "ready" position and the specimen. Sufficient distance should be allowed for the blade to decelerate to the preset speed before contacting the specimen.

The Lamp/Magnifier Assembly may be used to facilitate close observation of the specimen during sectioning.

#### 4.7 SECTION RETRIEVAL

Sections generated may be retrieved from the specimen bath by various means.

For microscopic applications, the section may be delivered to a glass slide by aspirating the section with a small glass dropper if doing so does not damage the specimen. In some cases, the usage of a fine sable brush is

more satisfactory since the risk of section damage is reduced. In other cases, an intermediate bath may be used so that the section may be floated onto a partially submerged glass slide.

The sable brush or a blunt glass rod may be used to manipulate the section while it is in the specimen bath.

Once the section is positioned properly onto the glass slide it may be adhered with albumin or other mounting media. Staining or other treatment, then cover slipping, may be performed as would be in the case of a typical conventional section for microscopy.

Upon completion of all sectioning, the specimen bath area should be cleansed as noted in the "Cleaning" section.

#### 5.0 SPECIFICATIONS

Size, Specimen	25mm x 25mm maximum area
Height Adjustment Assembly 5	10mm total travel; continuously adjustable; Vice calibrated in um increments; tactile click stops at um intervals.
Tilting, Specimen continuously Vice	-5 degrees to +5 degrees in one axis; adjustable; not calibrated
Type, Sectioning	Single edge injector type, or modified double edge Blade type razor, sapphire knife, glass knife with adapter, disposable microtome blades
Advance, Sectioning Blade	Forward – 0 to 1.25 mm/sec speed; continuously adjustable; not calibrated  Reverse – 1.25 mm/sec speed. Travel – 30 mm total.
Vibratory Movement, Sectioning Blade	Arcuate path, 0 to 1.25 mm total amplitude; continuously adjustable; not calibrated
Angle Adjustment Sectioning Blade	0 to 50 degree range; continuously adjustable; calibrated in 5 degree increments.
Vertical Specimen Stroke	10 mm with a steep angle adjustment
Dimensions	460mm depth x 280mm width x 310mm height
Weight	14.5 kg
Electrical Needs.	Product Number 054018 110 AC +/- 15% voltage; 50/60 Hz frequency; 1 amp maximum current  Product Number 054026 230 AC +/- 10% voltage; 50/60 Hz frequency; 0.5 amp maximum current

#### 6.0 ACCESSORIES

The following is a listing of accessories available at the time of this writing. This list may be expanded to include additional items in the future. Efforts will be made to inform users of significant additions.

#### 6.1 STANDARD ACCESSORIES

The following items are available from the distributor through which your Vibratome 1000 was obtained, or can be ordered directly from The Vibratome Company by calling 314-522-8671.

Description	Product Number
Mounting Block, Specimen (3 per package)	053747
Adhesive, Specimen	053986

Fluorescent Lamp, Cool White	053226
Blade, Single Edge Injector (84 per package)	053234
Specimen Tray	053744
V-Block Adapter	053750
Specimen Mounts ½ head	053753
Rotating Stage Assembly	053760
Replaceable Rotating Mounts	053763
Sapphire Knife	053237
Glass Knife Adapter	053237
Specimen Retrievers	053220
Section Mounting Device	053225

## 7.0 MAINTENANCE

The Vibratome 1000, in normal usage, should require very nominal maintenance. Observe the following when the need arises. Maintenance or service work beyond those listed in the following should be performed by qualified Vibratome Company service personnel. See the "Service" section for details.

### 7.1 COMPONENT REPLACEMENT

#### 7.1.1 Fuse

If the instrument fails to function completely, check first for power availability at the power outlet. The instrument fuse(s) located at the rear of the instrument should be checked next. Before removing fuse, DISCONNECT POWER CORD from outlet. The fuse and its holder are removed by rotating holder counter clockwise by one-quarter turn.

Observe to see if the filament within the glass tube of fuse is intact. If not, replace with SAME TYPE AND RATING fuse, two of which are supplied in the Accessory Package. Before reconnecting power cord, check the instrument for obvious cause of the burnt fuse and make appropriate correction.

#### 7.1.2 Fluorescent Lamp

When the fluorescent lamp fails to turn on or flickers when operating, replacement is necessary. The fluorescent lamp is located under the Lamp/Magnifier Assembly housing, directly behind the glass magnifier. DISCONNECT POWER CORD before removing lamp. The lamp is removable from its mounting sockets by rotating lamp tube by one-quarter turn in either direction. When replacing with new lamp, line up and insert both pins on both ends into sockets. Rotate one-quarter turn in either direction until lamp is firmly retained in sockets.

## 7.2 CLEANING

### 7.2.1 Specimen Bath Area

After completion of sectioning the specimen bath, specimen vise and sectioning blade holder should be cleansed of any accumulation of bath solutions. Any water-soluble solvent may be used unless it attacks polypropylene or nitrile rubber. The final flushes should be clean water. This procedure should insure against premature corrosion of metal components in the area, accumulations of slats or contamination of subsequent baths.

### 7.2.2 Magnifier Lens

The lens in the Lamp/Magnifier Assembly is best cleaned with soft tissue moistened with ethyl alcohol or common glass cleaners. A final buffing with clean dry tissue should follow.

### 7.2.3 Cabinet

Any liquids spilled on the instrument should be wiped immediately. Periodic wiping with a mild non-abrasive cleanser is suggested. A vinyl instrument cover is provided in the Accessory Package for protection against dust or scratching between usage.

## 8.0 SERVICE INFORMATION

### 8.1 LIMITED WARRANTY POLICY

The Vibratome 1000 instrument is warranted against defects in material and workmanship in normal use for a period of one year. The one-year period begins on the date of invoice from The Vibratome Company or its associated distributor.

The Vibratome Company's liability under this warranty shall not exceed the amount invoiced and adjustments shall be limited, at the Company's option, to repair, replacement, or credit at the purchase price of the instrument.

Adjustments shall be contingent upon inspection of the instrument to determine that defects have not been caused by misuse, abuse, improper application, repair, alteration, accident or negligence in use, storage transportation or handling, and that original identification markings have not been removed, defaced or altered.

During this warranty period, adjustments for defects found attributable to material and workmanship shall be at The Vibratome Company's expense. Expenses incurred by the user in the return of the instrument for adjustment shall also be reimbursed by The Vibratome Company.

Claims made regarding this warranty when within the United States shall be addressed with:

The Vibratome Company  
 Attn: Technical Service Department  
 5918 Evergreen Blvd  
 St. Louis, MO 63134  
[www.vibratome.com](http://www.vibratome.com) support@vibratome.com  
 Or by calling :314-522-8671  
 Fax: 314-522-6360

Claims made regarding this warranty when NOT within the United States shall be addressed with the distributor through which the instrument was obtained.

### 8.2 SERVICE POLICY

For service problems beyond those outlined in the "Maintenance" section, and when within the United States, call the Vibratome Company Technical Service Department. A service representative may resolve the problem by pacing the user through basic checkout procedures.

If the problem cannot be resolved in this manner, the instrument should be returned to the above address for service. The instrument should be packaged securely in its original carton for return to preclude in-transit damage. If you do not have the original carton, one can be shipped to you at an additional nominal cost to minimize the potential for costly shipping damage.

Prior to all returns, Return Authorization shall be obtained by calling The Vibratome Company Technical Service Department.

For service problems beyond those outlined in the "Maintenance" section and when NOT within the United States, contact the dealer through which the instrument was obtained. Local service personnel at the dealer's disposal may resolve the problems. Otherwise, return of the instrument for factory repair may be arranged by the dealer.

All service repairs covered under the Warranty Policy shall be performed at no expense to the user. Out-of-warranty service repairs shall be at the user's expense. Labor, parts, and transit costs incurred shall be at prevailing rates at the time of repair.

## USE STATEMENT

The Vibratome is designed to be safe under at least the following conditions:

- Indoor use
- Altitude up to 2000m
- Temperatures 5 degrees C to 40 degrees C
- Maximum relative humidity 80% for temperatures up to 31 degrees C decreasing linearly to 50% relative humidity at 40 degrees C
- Mains supply voltage fluctuations not to exceed +/- 10% of the nominal voltage

### 8.3 ADDITIONAL HELP

The Vibratome Company maintains an extensive web site at [www.vibratome.com](http://www.vibratome.com). This web site contains a wealth of information for Vibratome users. The site contains the following resources

- Online Manuals
- Frequently Asked Questions
- Common Techniques
- New Product Information

- Product Comparisons
- Repair Procedures
- On-line Bulletin Board Service

For application questions that cannot be readily answered, try posting a message to researchers around the world on the web bulletin board system.